



ATTENZIONE:

gli operatori devono leggere e capire completamente questo manuale prima di utilizzare il prodotto.

ATTENTION:

the operators must carefully read and completely understand the present manual before using the product.

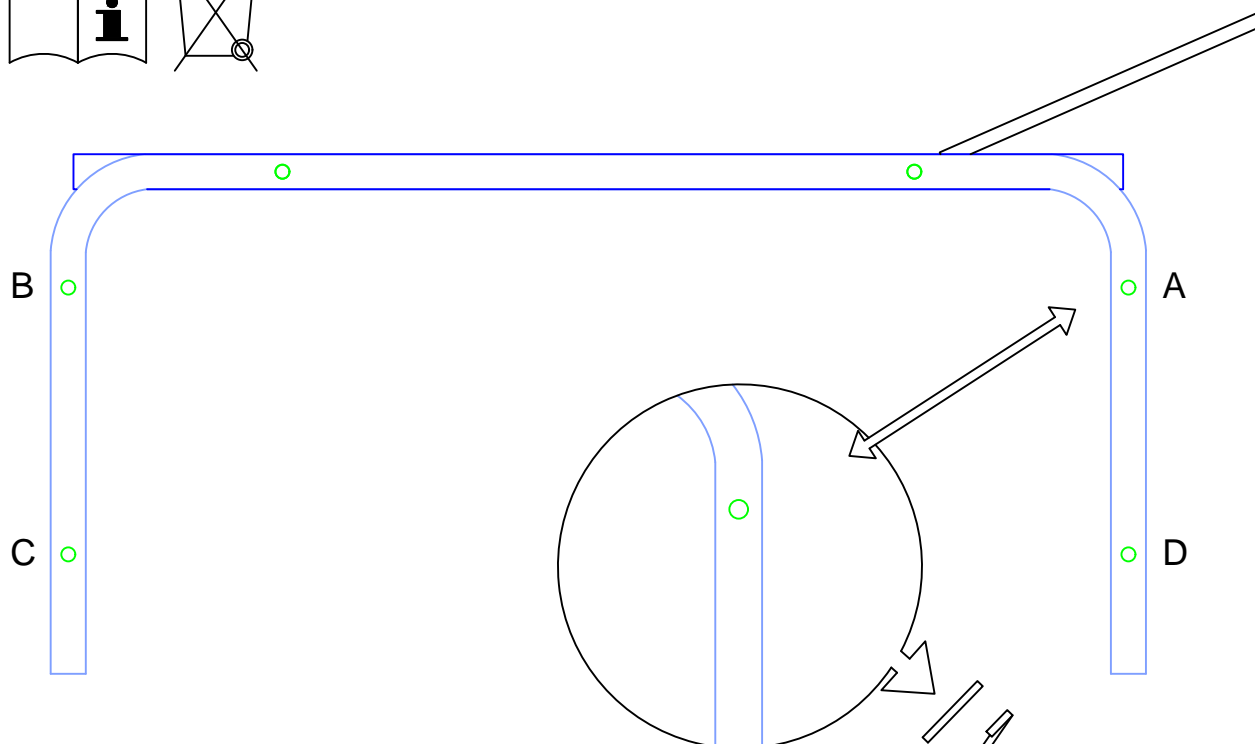
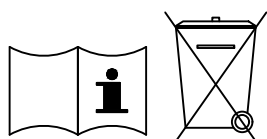

1. Dopo aver individuato la posizione migliore per il vostro porta rotolo tra le 4 possibili (A-B-C-D)

estrarre il tappo copri foro e le viti con relative rondelle (NON VI OCCORRERANNO PIU').

1. After identifying the best position for your roll holder among the 4 possible ones (A-B-C-D),

remove the hole covercap and the screws with the relative washers (YOU WILL NO LONGER NEED THEM).

OSSERVARE MOLTO BENE LA FIGURA A FIANCO PRIMA DI PROCEDERE
CON IL MONTAGGIO AL PUNTO 2.

OBSERVE VERY WELL THE FIGURE TO THE LEFT BEFORE PROCEEDING
WITH THE ASSEMBLY IN STEP 2.



Caldara s.r.l.
Via Trieste 31/b
22036 Erba (Co) ITALIA

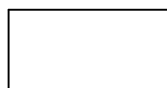

CALDARA

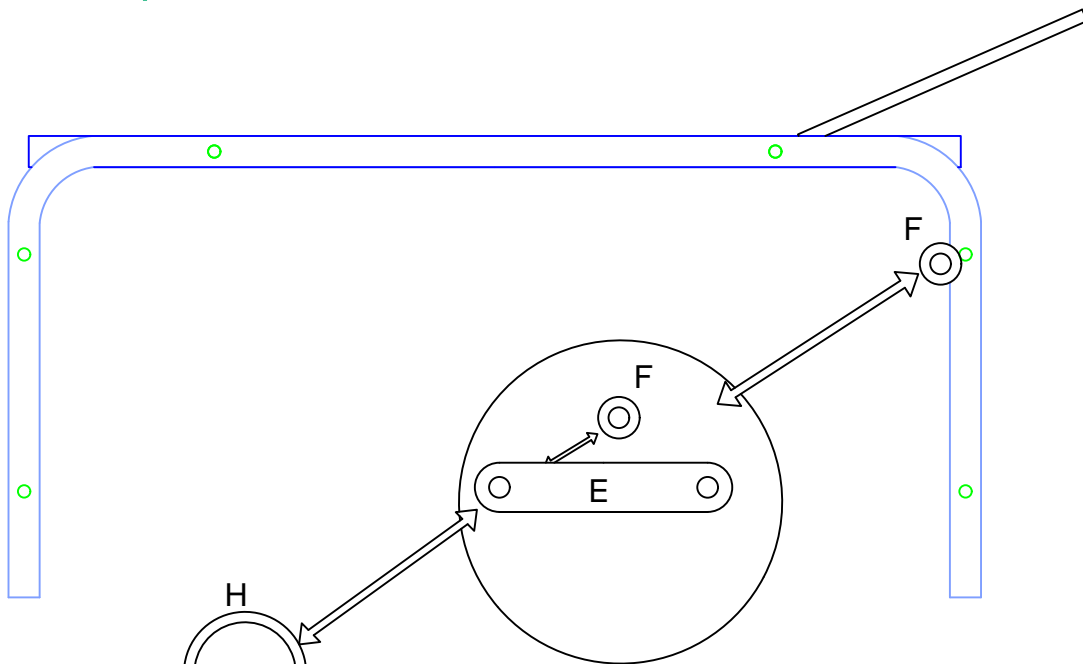

2. Posizionare il supporto del porta rotolo (E) all'esterno della gamba mettendo la rondella di plastica (F), utile a non rovinare la vernice, a contatto con la stessa; serrare da entrambe le parti utilizzando la vite a testa bombata (G) dopo aver inserito la rondella di metallo (H).
2. Place the roll holder support (E) on the outside of the legs by putting the plastic washer (F) in contact with it, to preserve the integrity of the paint. Tighten on both sides using the pan head screw (G) after inserting the metal washer (H).

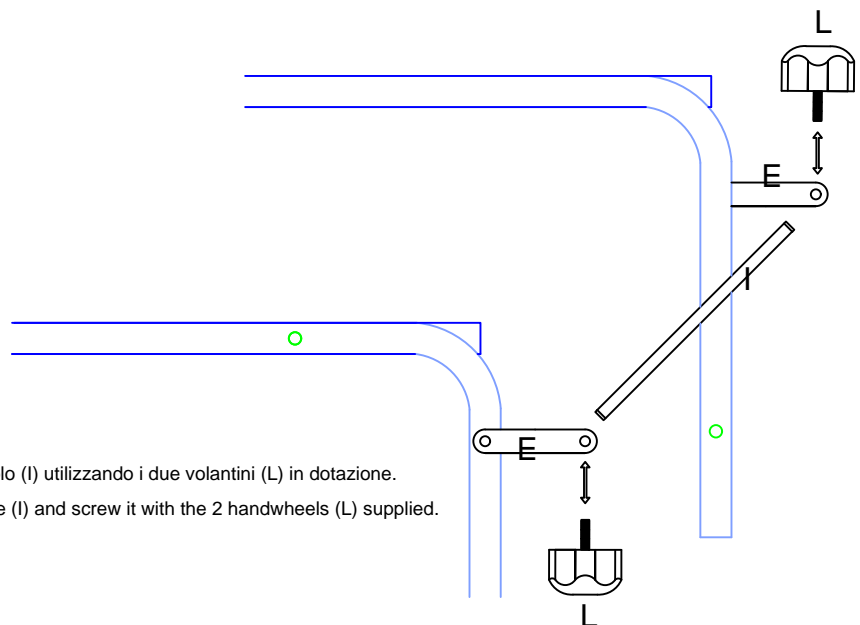

3. inserire il tubo porta rotolo (I) utilizzando i due volantini (L) in dotazione.
3. Insert the roll holder tube (I) and screw it with the 2 handwheels (L) supplied.

